

KUNDT'S APPARATUS (with speaker & mic)

Cat: SW1996-001 Kundt's apparatus

DESCRIPTION: This apparatus is used to reproduce Kundt's experiments to study wave motion inside a tube by using sound and by creating 'standing waves'.

COMPONENT PARTS:

- 1x Transparent tube, 50mm dia.x 820mm long with transparent scale fitted. Tube is complete with 2 holes and sliding covers for work on resonance.
- 2x Support blocks to hold the tube horizontally up from the work bench. One support grips the tube and holds the speaker, the other support grips the tube and contains a guide for the piston and microphone as it slides inside the tube.
- 1x Piston on a long rod to create various length closed tubes.
- 1x Microphone and cable on long blade to pass through a slot in the piston and to place the microphone to any position along the tube.
- 1x Buffer unit to interface the microphone to an amplifier or oscilloscope.

SW1996-001 Kundt's apparatus



ADVANCED FEATURES OF THE 'IEC' UNIT:

- The 2x holes provided in the tube can be covered by sliding covers.
- The scale can be read when either on the upper side of the tube or the lower side of the tube (for measuring the microphone position). Twist the tube to move the scale.
- The parts remove easily from the tube to be re-packed for storage in the classroom.
- The speaker is fitted with protection circuit to avoid damage to the speaker if too much power is applied from the signal source. **NOTE:: small speakers can easily be destroyed by too much power, so this feature is very important.**
- The microphone is sensitive and strong. The microphone support blade is fibreglass.
- The strong piston is a good fit in the tube and the piston support rod is fibreglass.
- The Microphone buffer with standard 9V battery with very long life (several years) and the circuit is turned ON as the microphone plug is inserted. If the LED is on when plug is inserted, the battery is OK. Removing the plug, turns OFF the circuit.

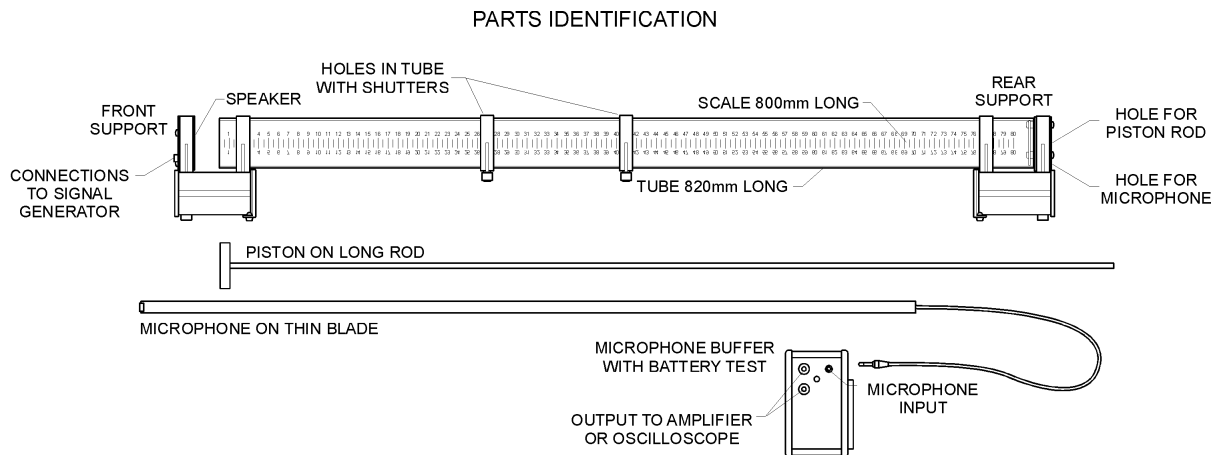

HOW IT WORKS: Look at the drawing above to see the various parts of the Kundt's Apparatus. Variable length air column with loud speaker to create the sound waves and miniature microphone to detect the nodes and antinodes inside the tube.

ASSEMBLY FOR AN EXPERIMENT:

- Take the piston on the long rod and take the miniature microphone on the long blade. Slide the microphone support blade into the slot in the piston so the microphone is in front of the piston face. See pictures on front page. Slide the piston and microphone together up the tube from the 800mm end until it is about half way along the tube.
- At the 'zero' end of the tube, take the 'speaker' and stretch the clip over the tube. Slide it forward until the speaker disc is touching the end of the tube.
- Take the plain support block (without the 2 sockets) and, with the spring clip facing the 800mm end of the tube, insert the piston rod through the central hole and thread the microphone cable and blade through the notch provided. Stretch the clip over the tube and slide the system forward until the piston rod guide disc enters the tube.
- Place both support blocks on the table and gently press down so the rubber feet rest nicely on the table.
- Now slide support block until the speaker is about 10mm away from the end of the tube. For normal experiments, the end of the tube must NOT touch against the speaker. **REASON:** The experiments are performed on either an open tube (open both ends) or on a closed tube (tube closed at the end opposite the speaker). When the piston is slid inside the tube, the piston forms the closed end at any position along the tube. Connect the 2 sockets on the speaker housing to a sine wave signal source (oscillator or similar) with standard 4mm banana plug cables.

SIGNAL SOURCE: Set your oscillator to about 500Hz and check that the speaker performs properly. The speaker is protected against too much power from the signal source, but the sine wave signal should be about 1 to 2 volts peak. If your oscillator cannot provide enough power, an amplifier may be required to drive the speaker. Or use one of the IEC Signal Generators: LB3754-001 or the famous TriMode LB3758-001 or the advanced 'WaveLab' LB3756-101.

IMPORTANT NOTE: If the voltage to the speaker is too high, the wave will be distorted and will no longer be a sine wave shape. If this occurs, the sound from the speaker will be distorted and will not sound ‘clean’.

- **During an experiment, the speaker does not need to be loud.** The sound wave will be detected by the microphone. Gently slide the mini microphone through the slot in the piston so that it moves inside the tube. The tube can be rotated in the clips so the scale is at the bottom and close to the microphone for accurate measurements.
- The piston can be slid along the tube to make the closed tube any length desired.
- During certain experiments, the two spring shutters can be slid from covering the holes in the tube to open the tube at these places.

MICROPHONE BUFFER: Insert the microphone plug into the socket provided on the ‘Microphone Buffer’ and, using standard 4mm banana plug cables, connect the buffer to an oscilloscope to see the microphone signal or into an amplifier to hear the microphone signal. Note that the IEC ‘TriMode’ LB3758-001 includes an audio amplifier. The battery is always tested if the LED is ON when the microphone plug is inserted.

BATTERY: To replace the standard 9V battery, open the compartment on the side of the buffer. The battery has a very long life and will last several years providing the microphone is disconnected from the buffer when storing the instrument.

WAVELENGTH AND FREQUENCY CONVERSION: To convert Frequency to Wavelength or to convert Wavelength to Frequency, the following formula must be used:

$V = \lambda f$ where V is speed of sound in air in metres/sec, λ is wavelength in metres and f is frequency in Hz. For school experiments, the speed of sound can be considered to be close to 342 metres per second.

Far end of the Kundt’s tube showing the mini microphone on the long blade plugged into the microphone buffer.



Designed and manufactured in Australia



EXPERIMENTS: There are many experiments that can be performed with the Kundt's Tube (or Resonance Tube) and the following experiments are simple examples.

INTRODUCTION:

When a speaker cone vibrates to make sound, it squeezes the air forward and then stretches the air backwards many times per second. This motion causes the air to move forward away from the speaker and to form small areas of high pressure followed by small areas of low pressure following each other.

The pulses of air pressure along the tube are similar to the appearance of the vibrating coils of the fat 'slinky' spring used in wave demonstrations along the floor.

The pattern of air pressures is normally radiated widely from a speaker but in the case of the Resonance Tube, the pulses are held inside a parallel tube. A longitudinal wave pattern of high and low air vibrations and high and low air pressures is created and, if a sine wave is supplied to the speaker, the wave pattern inside the tube will also be a sine wave.

STANDING WAVES:

Standing waves are easily seen when vibrating a string which is tied to a point and pulled into tension. When the tension of the string and the frequency of the vibration is correct, the string appears to stop moving but takes a sine wave shape. The wave reflecting back from the fixed point interferes with the wave coming forward and the two waves add or subtract from one another vibration in the string appears to become stationary. This is a "standing wave" and the 'nodes' and 'antinodes' can very easily be seen. As the tension is changed or if the frequency is changed, the number of 'nodes' changes.

A 'node' is where the string vibration amplitude is zero and an 'antinode' is where the string is vibrating with maximum amplitude. The same thing occurs in sound but the 'nodes' and 'antinodes' cannot be seen. However, they can be detected by 'hearing' the vibrations with a microphone or by seeing the vibrations on an oscilloscope.

"DISPLACEMENT" NODES:

There are positions along the tube where there is little or no movement or vibration (or displacement) in the air. Displacement antinodes are the positions where there is maximum vibration.

"PRESSURE" NODES:

There are positions along the tube where there is little or no extra air pressure. Pressure antinodes are the positions where there is maximum air pressure.

NOTES: Displacement & Pressure:: At the positions where there is maximum air vibration, there is minimum air pressure and where there is minimum air vibration, there is maximum air pressure. Therefore, displacement nodal positions are pressure antinodal positions and displacement antinodal positions are pressure nodal positions.

Standing Wave:: For a standing wave to occur, there must be a reflection of the applied wave backwards to interfere with the original wave moving forwards.



OPEN TUBE: If the tube is open at the end, there can be no pressure at this point (a pressure node), so it follows that this is a point of maximum vibration or a displacement antinode.

CLOSED TUBE: If the tube is closed at the end, there must be maximum pressure at this point (a pressure antinode), so it follows that this is a point of minimum vibration or a displacement node.

Both open ended and closed tubes reflect at the end of the tube and the reflected wave will interfere with the forward wave. But when the frequency is adjusted so that the reflected wave synchronises with the forward wave to ADD to the forward wave, the sound is greatly amplified and this effect is called 'Resonance'.

RESONANCE: When sound reflects from the end of an open or closed tube, the reflected wave will interfere with the original wave multiple times and there is no pattern of addition or destruction of the original wave. When the frequency is set so that the reflected wave synchronises with the original wave there will be an adding and subtracting from the original wave so that the resulting standing wave will have a much greater vibration and strength than the original wave. This is resonance.

The various frequencies that cause resonance depend on the length of the tube. Note that for study in sound, the term "wavelength" is preferred to the term "frequency".

CALCULATIONS FOR RESONANCE: For a tube OPEN at both ends, the approximate relationship between wavelength of the sound wave and the length of the open tube is: $L = n\lambda/2$ and $n = 1, 2, 3, 4$, etc.

Where: L = length of tube, λ = wavelength of the sound wave. n = a constant.

For $L = 500\text{mm}$ long tube, resonance will occur at 1000mm wavelength (tube is $1/2$ of the wavelength), 500mm wavelength, 333.33mm wavelength, 250mm wavelength etc..

For a tube CLOSED at one end, the approximate relationship between wavelength of the sound wave and the length of the closed tube is: $L = n\lambda/4$ and $n = 1, 3, 5, 7$, etc

For $L = 500\text{mm}$ long tube, resonance will occur at 2000mm wavelength (tube is $1/4$ of the wavelength), 666.66mm wavelength, 400mm wavelength, 285.7mm wavelength etc.

NOTE:: These are approximate formulae because the exact resonance calculations are affected also by: 1) The diameter of the tube being used, 2) The wavelengths used in the experiment 3) The fact that the exact end of the tube is not the exact reflection point.

If experiments must be more exact, corrections can be made for these factors and experiments can be devised using the microphone to explore these factors.

CORRECTIONS for tube diameters: 'd' = inside diameter of tube.

For OPEN tubes: $L + 0.8d = n\lambda/2$ $n = 1, 2, 3, 4$ etc..

For CLOSED tubes: $L + 0.4d = n\lambda/4$ $n = 1, 3, 5, 7$ etc..



WAVES IN TUBES:

The following illustrations show the various waves and overtones that appear in tubes.

THE FUNDAMENTAL 'STANDING WAVE' INSIDE A TUBE:

In a closed tube, the standing wave is $\frac{1}{4}$ wavelength. The node is against the reflecting surface and the antinode is at the open mouth at the other end of the tube.

In an open tube, the standing wave is $\frac{1}{2}$ wavelength. Both open mouths cause an antinode to form at each so that the node must be between them at $\frac{1}{4}$ wavelength.

The 'First Overtone' inside a tube:

In both closed and open tubes, the next resonant point is an additional $\frac{1}{2}$ wavelength from the fundamental resonant point. In closed tube this is $\frac{3}{4}$ wavelength and in the open tube this is 1 wavelength.

The 'Second Overtone' inside a tube:

In both closed and open tubes, each resonant point is $\frac{1}{2}$ wavelength longer than the previous one. Examine the illustrations below and work out the wavelengths in each example.

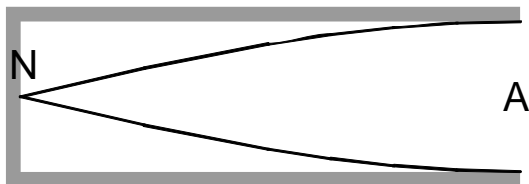

Fundamental: Closed Tube

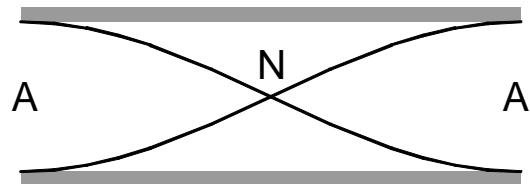

Fundamental: Open Tube

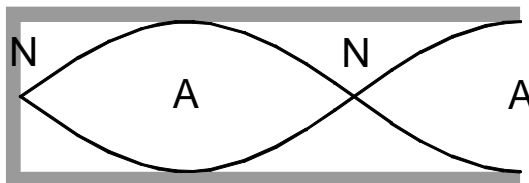

1st Overtone: Closed Tube

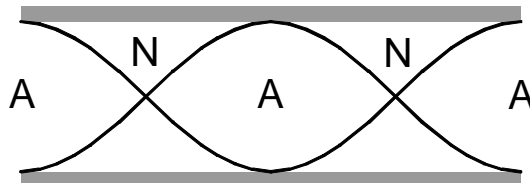

1st Overtone: Open Tube

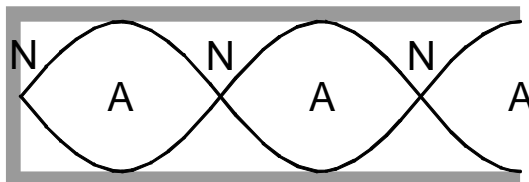

2nd Overtone: Closed Tube

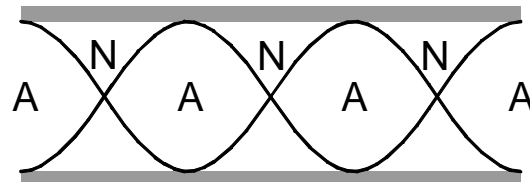

2nd Overtone: Open Tube

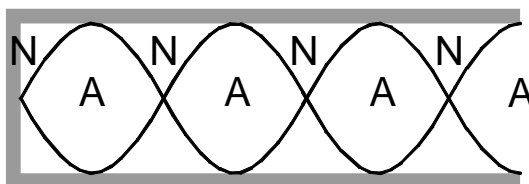

3rd Overtone: Closed Tube

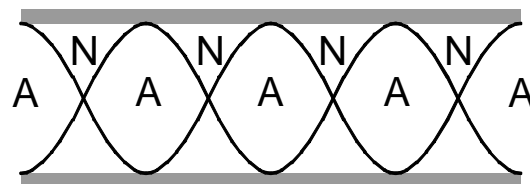

3rd Overtone: Open Tube

EXPERIMENT 1: RESONANT FREQUENCIES IN AN OPEN TUBE:

SETUP: NOTE: the overall length of the open tube is 820mm.. Use a signal generator to provide a sine wave to the speaker at a voltage of up to 2V peak. The resonant points should be heard by ear without needing the oscilloscope, however, if you wish to view the sound waves on an oscilloscope, you must use the microphone and also the 'microphone buffer' to the oscilloscope.

When resonance occurs, the energy of the sound wave is increased and the sound in the tube becomes louder. The speaker must be clearly heard, but it should not be too loud or it is more difficult to hear the resonant points at the lower frequencies.

Because the speaker is small, it is more efficient at higher frequencies, so it might be necessary to reduce the volume as the frequency rises. Set your sine wave oscillator to about 90Hz and be sure the tube is about 10mm away from the speaker housing. Leave the other end of the tube open. Adjust the signal so the speaker can be heard.

The microphone can be used and positioned just below the speaker to detect the loudest sound as the frequency is slowly increased.

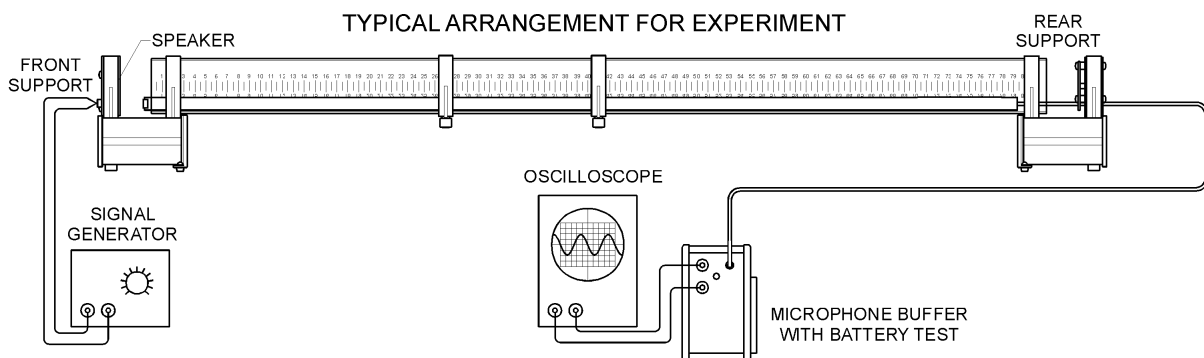
**EXPERIMENT:**

Start at about 90 Hz and gradually increase the frequency of the signal until you hear a sudden increase in volume in the tube that reduces when you increase the frequency slightly more. Then go back slightly to find the highest sound level from the tube. Take note of this exact frequency. This is your first resonant frequency #1.

NOTE: When the frequency is very low (about 100Hz or less) the sound is quite difficult to hear and the resonance change in volume is only slight. Listen carefully when the frequency is low.

Raise the frequency slowly to find the next resonant frequency and note the exact value as frequency #2.

Raise the frequency slowly to find the next resonant frequency and note this as frequency #3. Find a total of 5 or 6 frequencies for resonance in the open tube.

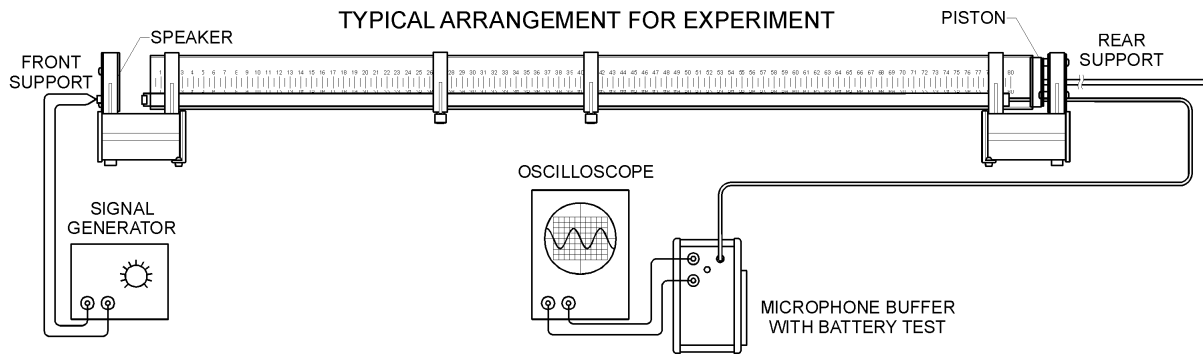

RESONANT FREQUENCIES IN A CLOSED TUBE:

Adjust the rear support so that it inserts into the tube and forms a 'closed tube' situation.

Set the frequency back to 90 Hz and repeat the above steps to obtain a set of resonant frequencies for a close end tube 850mm long.

Document your results as shown below:

Open tube Resonant freq.	Open tube Freq / Lowest	Closed tube Resonant freq.	Closed tube Freq / Lowest
#1 Lowest:	#1/#1	#1 Lowest:	#1/#1
#2	#2/#1	#2	#2/#1
#3	#3/#1	#3	#3/#1
#4	#4/#1	#4	#4/#1
#5	#5/#1	#5	#5/#1
#6	#6/#1	#6	#6/#1
#7	#7/#1	#7	#7/#1

Results: Look at the results of the resonant frequency divided by the lowest resonant frequency. The lowest frequency should be the fundamental frequency for the tube length of 850mm. All other resonant frequencies should be a multiple by whole numbers. The whole numbers should be different for the open tube compared with the closed tube.

If not, check the first resonant frequency again. It is possible that you have missed it because of the low frequency sound and the fairly quiet speaker.

If you cannot determine the lowest frequency, look at your results for the other frequencies and try to determine what the lowest or fundamental resonant frequency would have been.

Additional exercise: Repeat the 'Closed End' tube experiment, but slide the piston into the tube up to say the 600mm mark on the scale. Repeat the resonance experiment using this closed tube length. Document your results as shown above.

What do you notice about the dividing of the lowest resonant frequencies into the other resonant frequencies ?

EXPERIMENT 2: EXAMINING “STANDING WAVES”:

SETUP: This setup is the same as the previous experiment. But, in this experiment we will create standing waves and we will use the microphone at different places along the inside of the tube to examine nodes and antinodes.

NOTE: Microphones operate by pressure on a diaphragm, so the nodes and antinodes we will be finding with the microphone will be **pressure nodal points**. Refer to the introduction at the beginning of these notes for **explanation of the difference between ‘Displacement nodes’ and ‘Pressure nodes’**.

When a sound wave is produced inside a tube, the waves reflect from both ends of the tube so that some waves are moving forward and the reflected waves are moving backwards. These waves are constantly interfering with one another but when the reflected wave is synchronised with the forward wave, the two waves reinforce one another and the tube ‘resonates’ at that frequency. When these waves are ‘synchronised’ the waves can be said to be **‘in phase’** and a **‘Standing Wave’** pattern if formed inside the tube where the resultant wave appears to be stationary.

This experiment will create ‘Standing Waves’ and the microphone placed inside the tube will allow investigation into these waves.

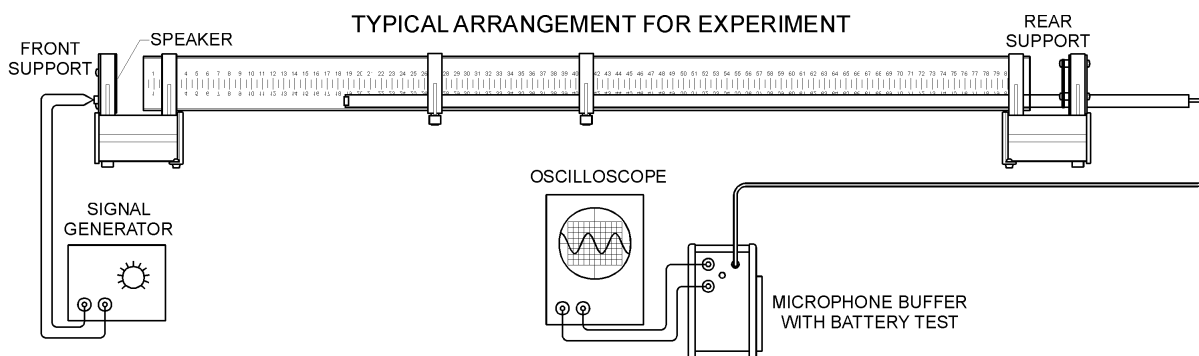
THE EXPERIMENT FOR AN OPEN TUBE:

Increase the drive to the speaker until the sound is clearly heard. Do not over-drive the speaker or the sound will become distorted. To prevent destruction of the small speaker, it is protected electrically against excess power.

Gradually increase the frequency until a sudden increase in sound level is heard. Then shift the frequency slightly more and then slightly less to check that you definitely have found a resonant point.

While the open tube is resonant, pass the small microphone through the hole provided under the speaker so that the microphone passes down the tube. Connect the microphone plug to the ‘Microphone Driver’ and connect the driver to the oscilloscope or an amplifier to detect sound.

The tube can be twisted in its supports so that the scale is at the bottom of the tube so the microphone position can be easily measured against the scale.



1. As the microphone is moved along the tube, notice the large changes in signal showing on the oscilloscope or heard on the amplifier. Record the frequency used and positions of the maximum and the minimum sound levels along the tube from the speaker end.
2. Increase the frequency and repeat the experiment.
3. Change the frequency several times and record the distances as before.

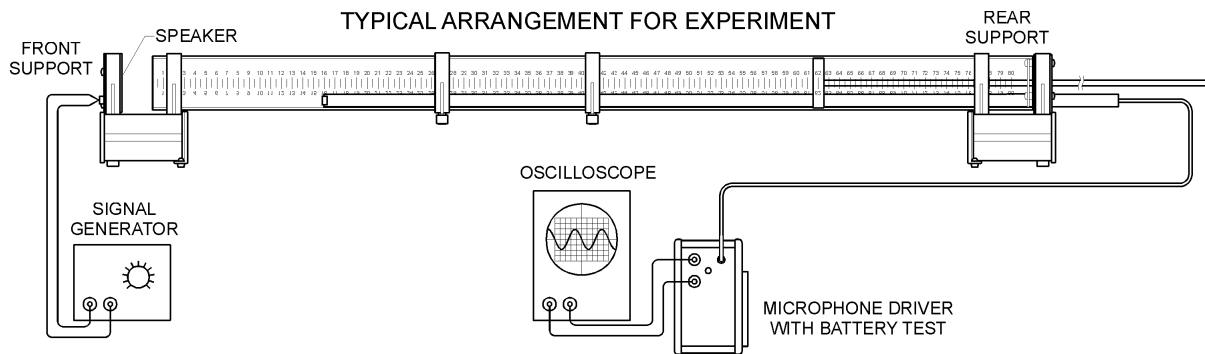

THE EXPERIMENT FOR A CLOSED TUBE:

Place the piston into the tube to form a ‘closed tube’ and position it about 1/3rd along the tube. Note the length of the closed tube.

Adjust the frequency to find a resonance point and repeat the microphone position measurements as you did in the open tube experiment.

Repeat the microphone measurements for several different frequencies that cause resonance in the closed tube.

Document all the results as shown below::

RESONANT FREQ:

RESONANT FREQ:

Open tube mic. positions Maxima	Open tube mic. positions Minima	Closed tube mic. positions Maxima	Closed tube mic. positions Minima



EXPERIMENT 3: RESONANCE AT DIFFERENT TUBE LENGTHS:

In experiment 1: we obtained resonance in an open and a closed tube with a fixed length of 820mm and we found the various resonance points by changing frequency of the sound wave. In this experiment, we will again be finding resonant points, but we will be keeping the frequency of the sound wave constant and we will be changing the length of the tube by using the piston.

SETUP: Connect the speaker to the tube and be sure the speaker is not too close to the end of the tube. Connect the microphone to its buffer and connect the driver to an oscilloscope. Slide the microphone to the end of the tube so it is just below the speaker and have it lie inside the tube.

Connect the speaker to a sine wave generator, set the frequency to about 800Hz and raise the power so the speaker is easily heard but not so loud that the speaker distorts..

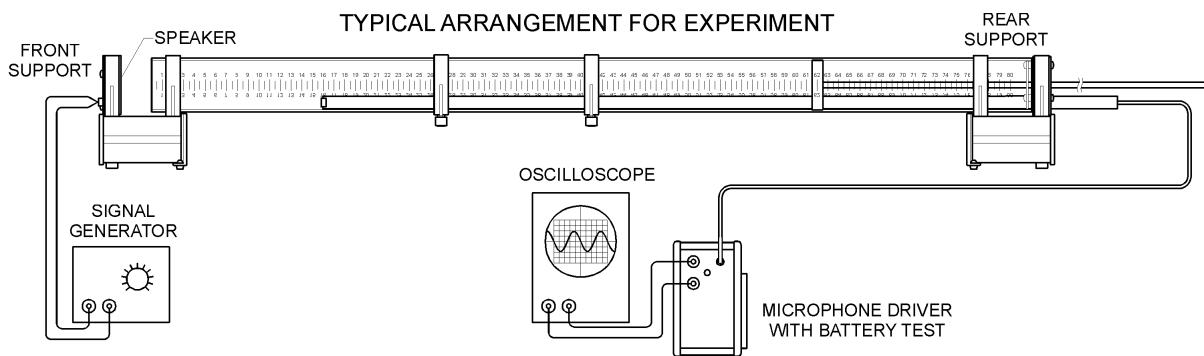

1. Place the piston in the tube and very slowly move the piston into the tube to find the exact closed tube length where the sound suddenly is louder. This occurs when there is a 'standing wave' in the tube or when the tube is 'in resonance'. The microphone or your ear can be used to find the sudden increase in sound level.
2. Keep moving the piston inwards and document all the tube lengths where resonance occurs. Note the frequency used. Repeat the above exercise three times using different frequencies of say 1200Hz, 2000Hz, 2500Hz. Document the results as shown below:
3. Calculate the wavelength of each of the sounds chosen in experiment 3. Check the positions of the piston (length of a closed tube). Compared with one wavelength, what is the distance between the different resonant tube lengths.

Hz: Hz: Hz: Hz:

Piston pos'n	Piston pos'n	Piston pos'n	Piston pos'n

EXPERIMENT 4: SPEED OF SOUND IN A TUBE:

Method 1): If a 'Standing Wave' is created in a tube, the wavelength of the sound wave can be calculated from the pattern of the standing wave.

If the frequency and the wavelength are known, the speed of the sound can be calculated by: $\lambda = V / f$ or $V = \lambda f$ where V is speed of sound in air in metres/sec, λ is wavelength in metres and f is frequency in Hz.

Method 2): If a sound pulse is sent down the tube and reflected from the end of the tube, if the length of the tube is known and the time between the pulse and the reflection is known, the speed of sound can be measured.

METHOD 1): Set the system as shown in the diagram below.

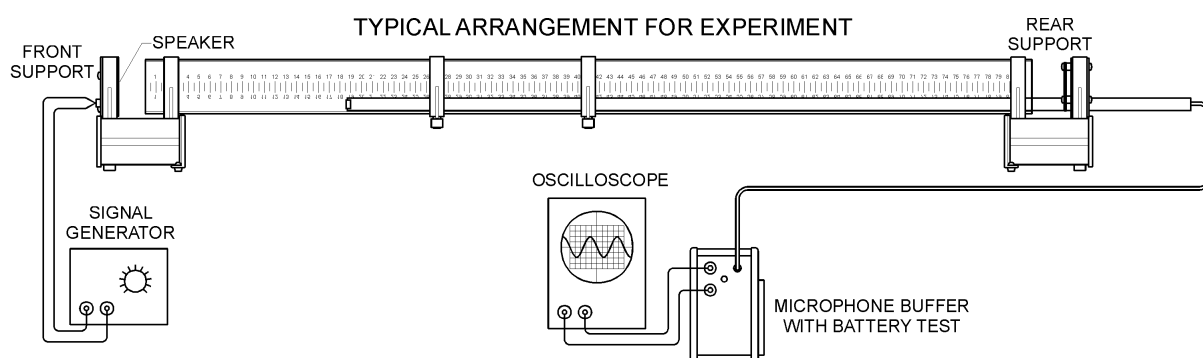

Adjust the frequency until a standing wave is produced and pass the microphone down the tube to find the pressure nodes or pressure antinodes. Slide the microphone to find the exact distance between nodes in metres. We know that the distance between nodes is one half of a wavelength, so multiply this by 2 to find the wavelength in metres.

Use the formula: $V = \lambda f$ to find V (the speed of sound) in metres per second.

METHOD 2): Now place the microphone at the end of the tube near the speaker.

Set the signal generator to provide square waves so that a series of sharp pulses is applied to the speaker instead of a gentle sine wave. Set the frequency to about 5 Hz.

The sharp pulses will be transmitted to the air in the tube and the reflected pulse will be seen by the microphone as a peak close to the applied pulse. There will be several peaks as the sound pulse reflects back and forth along the tube from both ends.

Using the Oscilloscope, measure the time in milliseconds between the second and third adjacent pulses (ignore the first pulse). This should be the time from entering the tube to reflecting back to the microphone (2x the length of tube or 1.64 metres).

Knowing this time taken for a pulse of air to travel 1.64 metres, calculate the speed of the sound pulse in air in metres per second.

The answer should be close to 342 metres/second.

**OTHER EXPERIMENTS:**

Other experiments can be performed using the versatile IEC's version of the Kundt's tube.

- 1) If a visual representation of nodes and antinodes is required, fine cork dust can be used to show a distribution of vibration patterns along the tube in the form of humps and valleys. Other very light powders can be used but cork dust is probably the least messy.
- 2) If dual frequencies are placed on the speaker by using the IEC 'Wave Lab', simulations of musical instruments can be performed. The opening and closing of the vent holes along the length of the tube can be seen to enhance certain wavelengths (or notes).

The function of the holes is to ensure that, inside the tube, that exact position becomes a point of lowest pressure and the resonant behaviour is forced to change accordingly. It shows the principles of the holes in a Flute, Recorder, Saxophone or Clarinet.

- 3) The IEC WaveLab LB3756-101 is a sophisticated source of very precise dual frequencies that can be changed in phase etc.. Using the WaveLab as the sound source could open new directions in teaching using the Kundt's tube.

Refer to your text books on Sound & Waves.

Designed and made in Australia